

The Add Tool

The **Add Tool** gives an alternative way of adding certain mesh primitives to our scene.

Although these primitives can be added anywhere in a scene, this tool is particularly useful when we want to add the new mesh to the surface of an existing object.

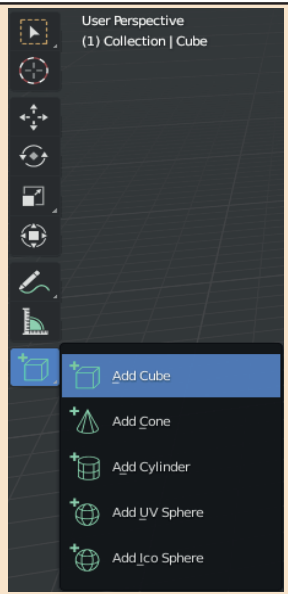

As we can see there are five options available, allowing us to add a Cube, Cone, Cylinder, UVsphere or Icosphere.

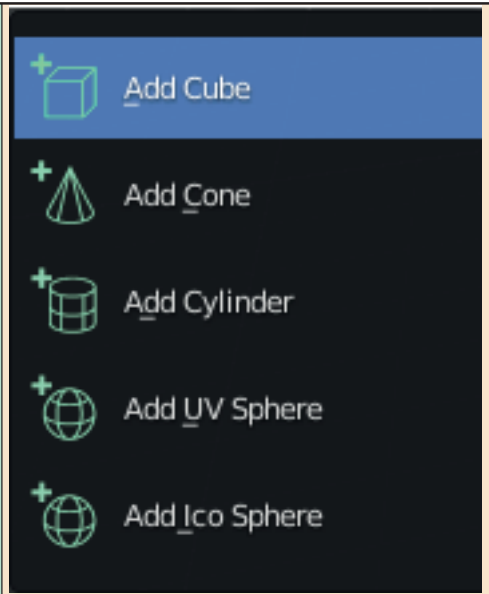

No matter which option we have chosen from the **Add Primitive** options, once we move the mouse pointer back into the 3D Viewport that mouse pointer changes into a grid as shown below.

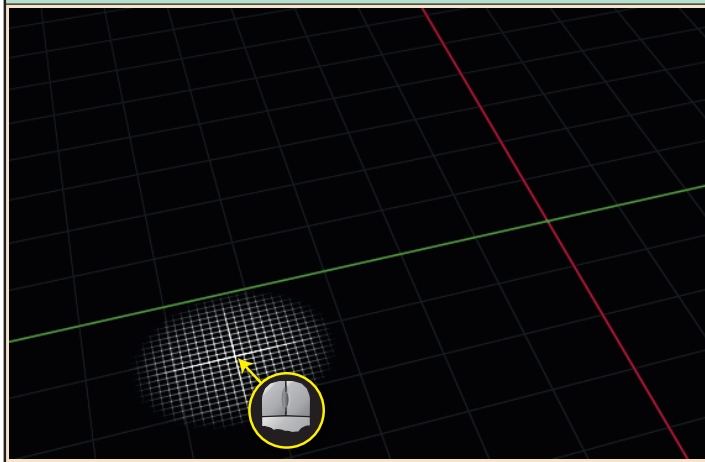

In the example below, **Add Cube** has been selected. One corner of the cube's base is selected by starting a mouse drag operation. The diagonally opposite corner is defined by releasing the mouse button.

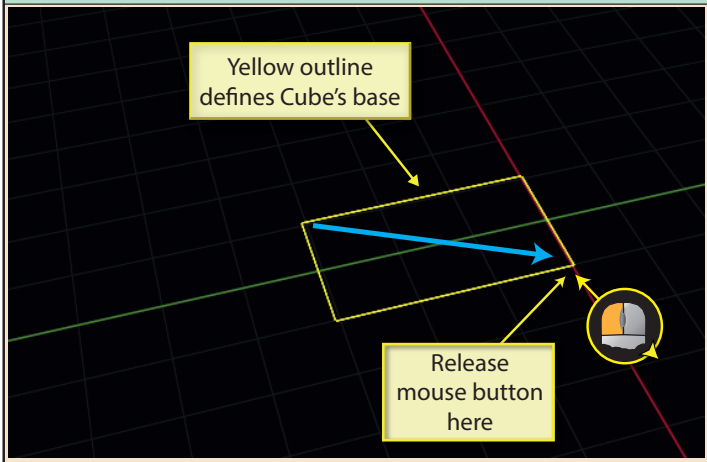

With the Cube's base defined, moving the mouse (with no buttons pressed) defines the cube's third dimension.

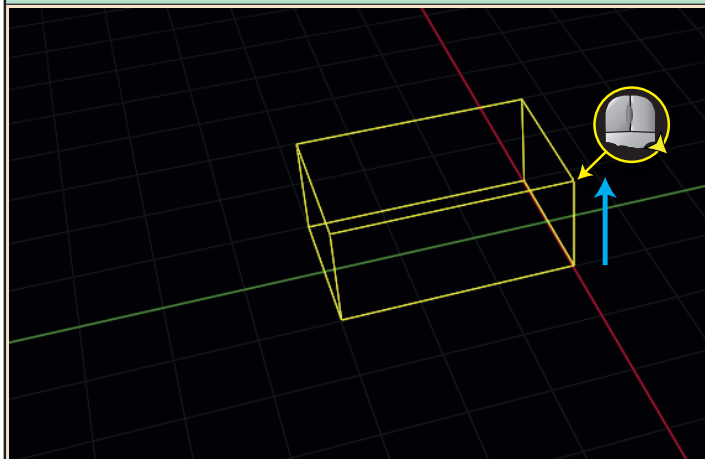

A final click of the mouse completes the operation and displays the Cube in solid mode.

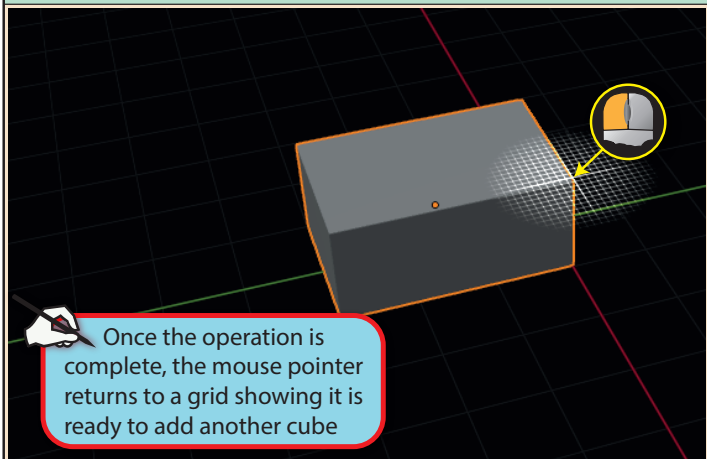

Like Cubes created with the **Add>Mesh>Cube** option, our newly created Cube, also creates an entry in the **Last Op** panel at the bottom-left of the 3D Viewport.

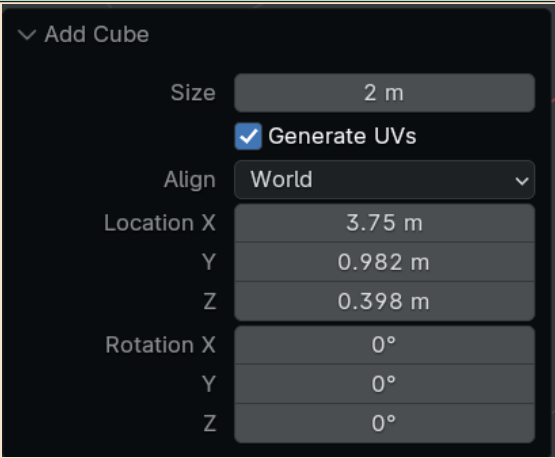

The **Size** setting in the **Last Op** panel is not really relevant since what we've just created is unlikely to be a true cube shape. Instead, if we want to modify its size, we can do this in the Sidebar.

Change size here

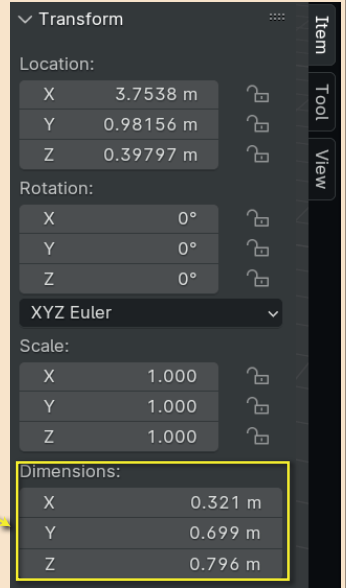

If we do make changes to the dimensions, we must remember to reset the scaling factors to 1.0 using the **Object>Apply>Scaling** menu option.

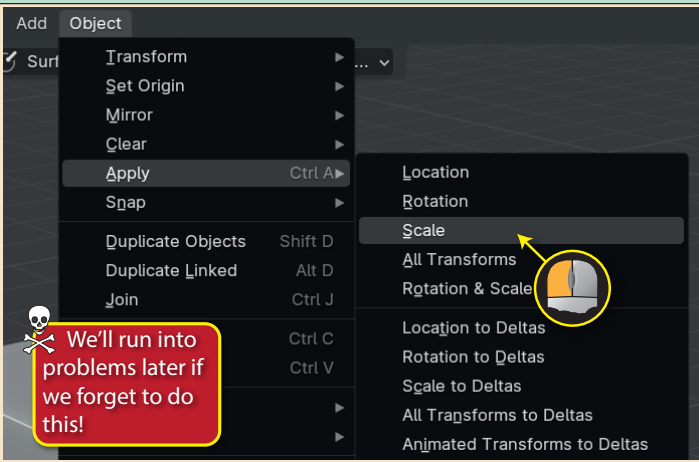

However, if we've set the Cube size solely by dragging to define the base and height, the Scale values will all remain at 1.0 irrespective of the Cube's actual dimensions.

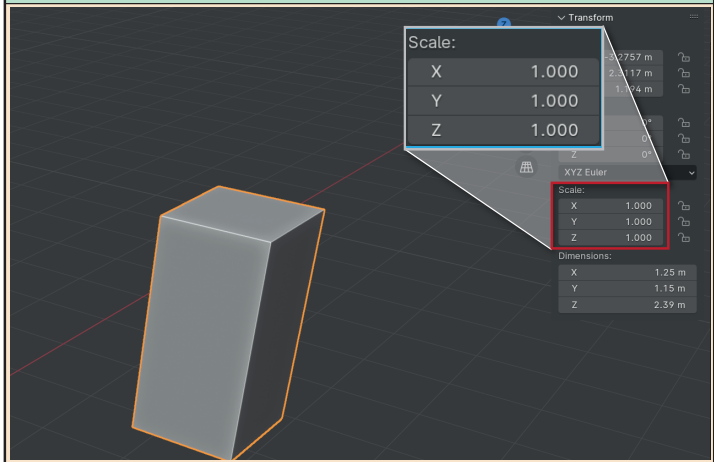

If we move the mouse pointer over the face of an existing object, the grid will realign itself to lie on that face.

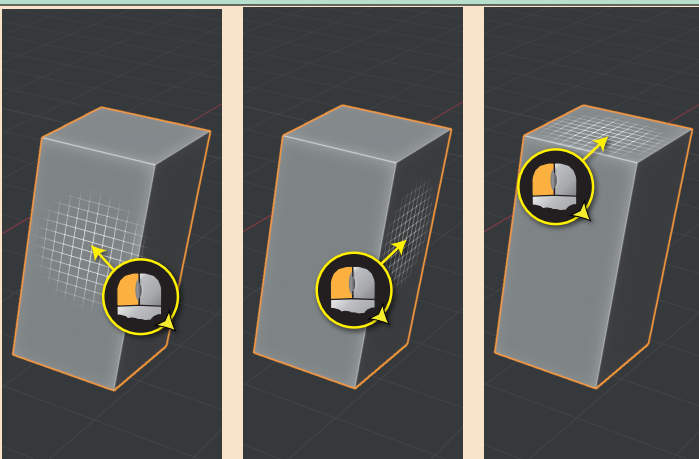

This means that, when we drag out a new Cube, its base lies flat on the existing face.

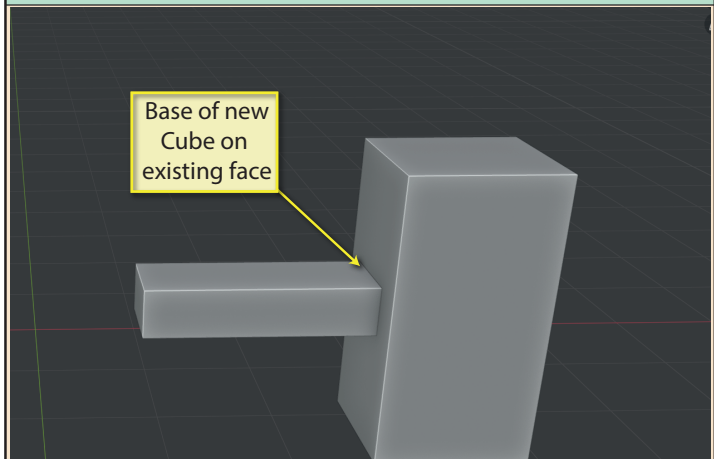

In the top-left of the 3D Viewport, there are additional parameters for the Add tool

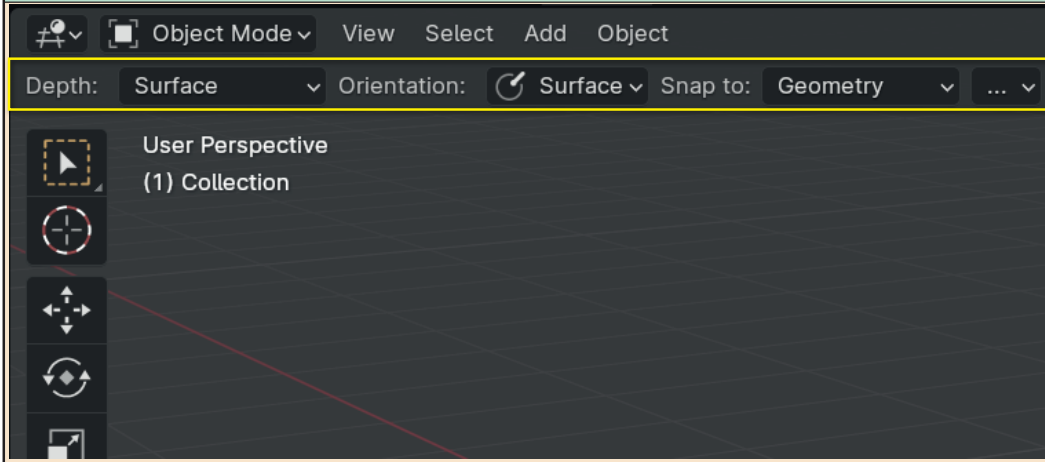

Depth determines the orientation of the new Cube's base.

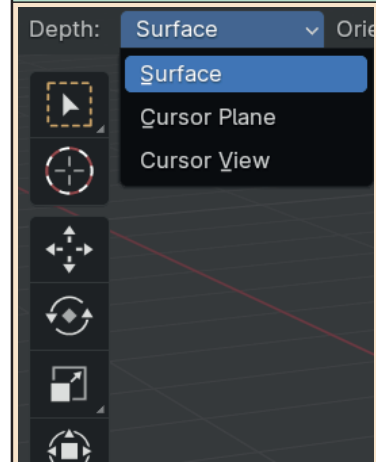

Surface is the default value, and, as we've already seen, it orientates the base to any face under the mouse pointer. When the new Cube is created away from an existing face, the base lies on the XY plane of the 3D cursor's axes.

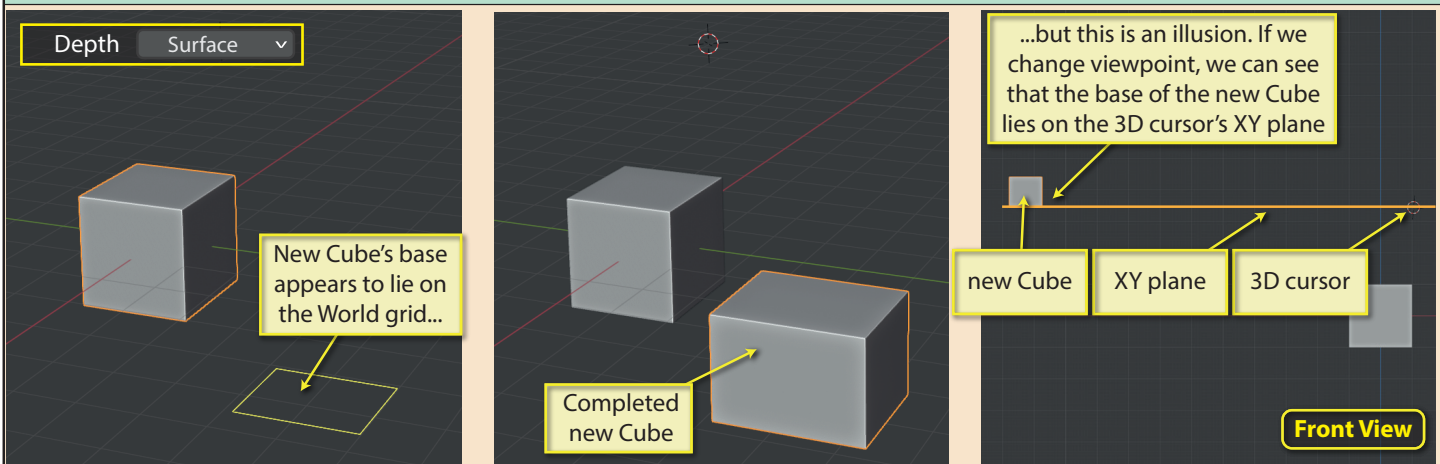

Cursor Plane is the next option for the *Depth* parameter. Using this option, the grid under the mouse pointer will reorientate itself when it moves over an existing face...

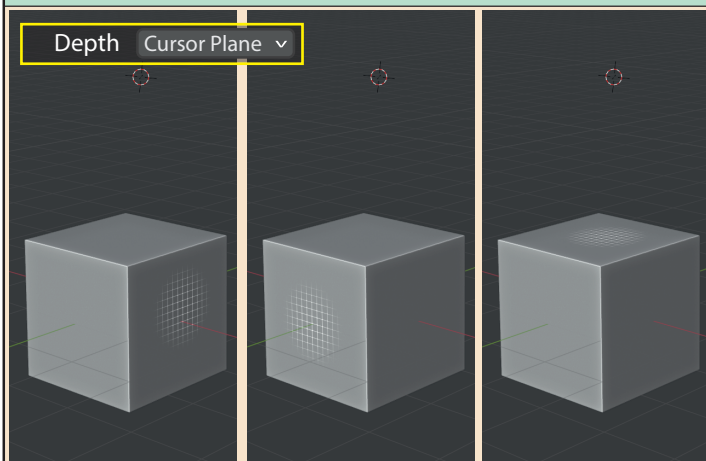

But any builds that appear to be on the surface of an existing object...

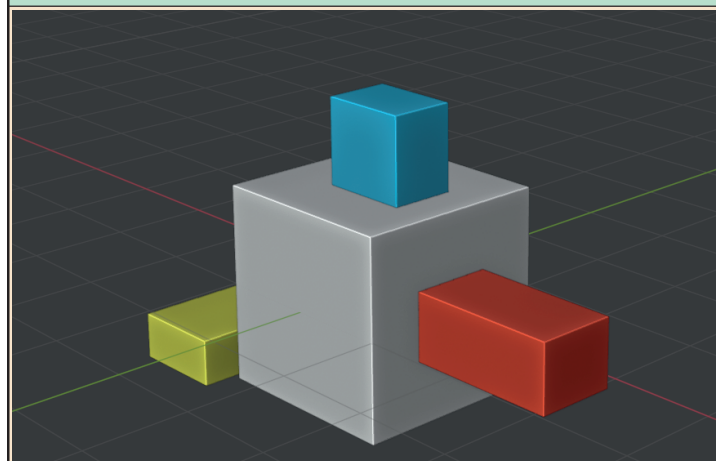

... are illusions which disappear when we change viewpoint.

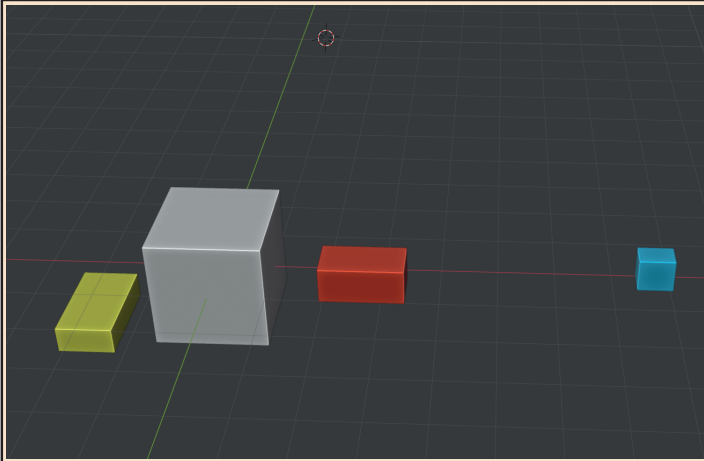

In fact, all of the new Cubes lie on one of the planes of the 3D cursor.

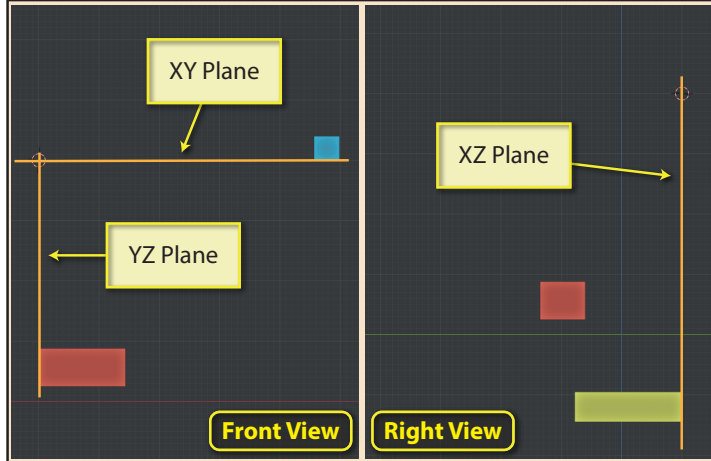

Cursor View is the last *Depth* value. To understand how this affects the positioning of a new Cube we'll need to create a Plane which is perpendicular to our viewpoint.

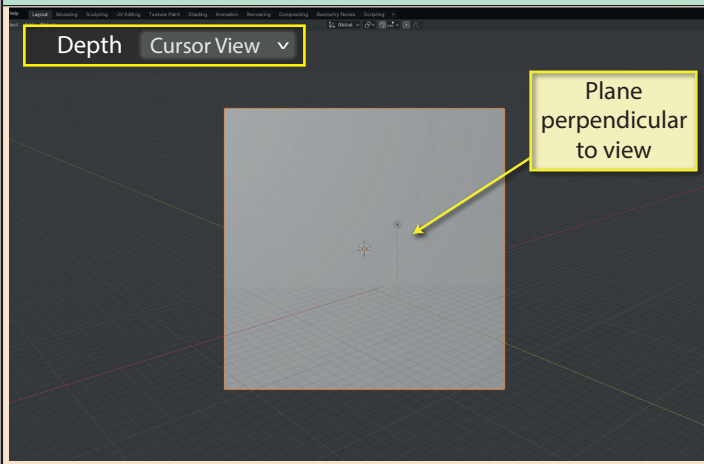

With the Plane hidden, we can see that the grid realigns itself as the mouse pointer moves over a face.

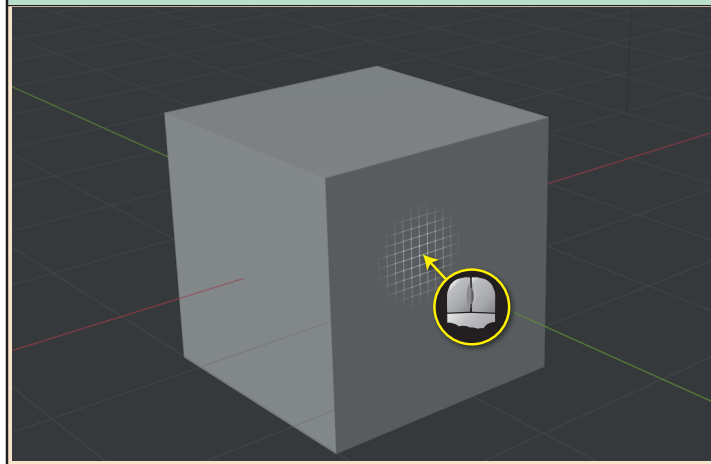

But when we attempt to sit new Cubes on the original one, again we see that the attempt has failed.

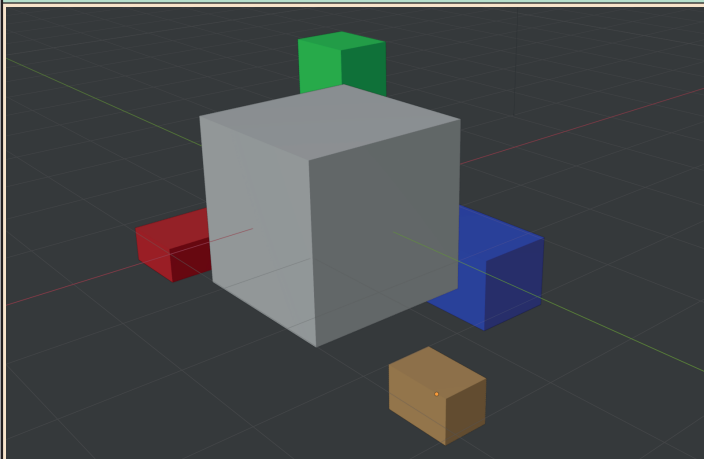

But if we reshew the Plane, we can see that at least one vertex of every new Cube sits on that Plane.

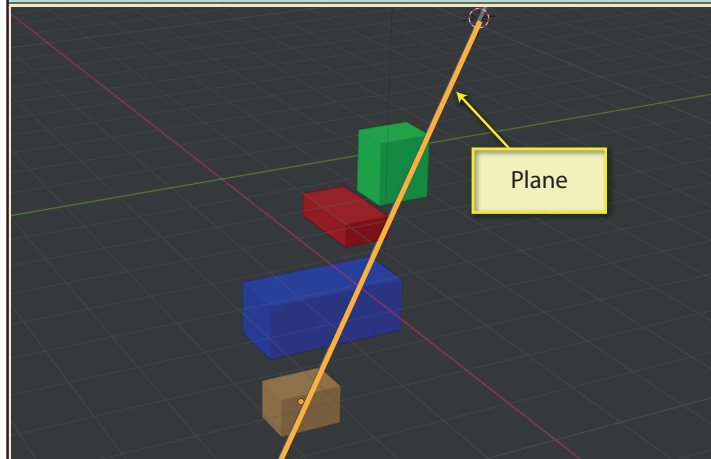

The next parameter is **Orientation**, which determines the direction in which the new Cube's Local axes lie.

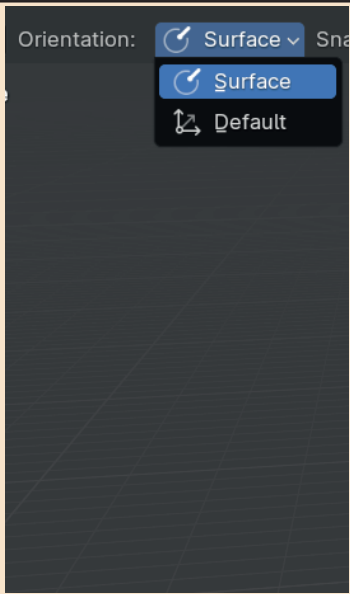

When set to **Surface**, the Local z-axis of the new Cube points in the same direction as the normal of the face it is positioned on.

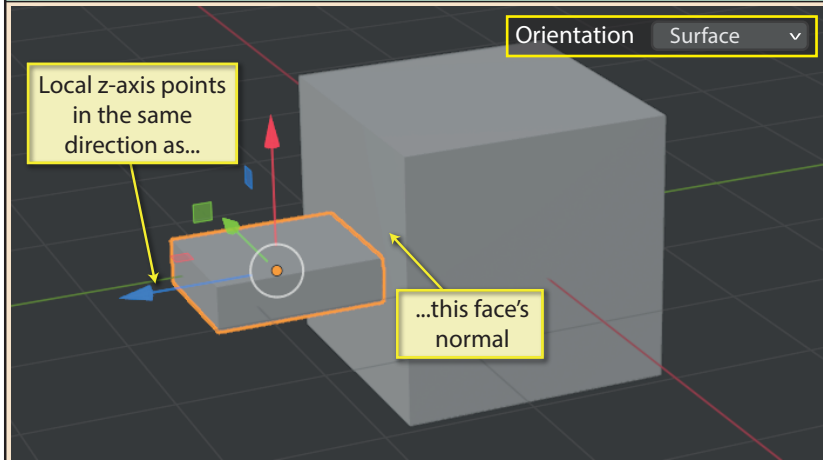

When the new Cube is not placed over a face, then its Local axes orientation is determined by the setting in the **3D Viewport's Transformation Orientation**. If this is **Global**, then the new Cube's Local axes are aligned with the World axes.

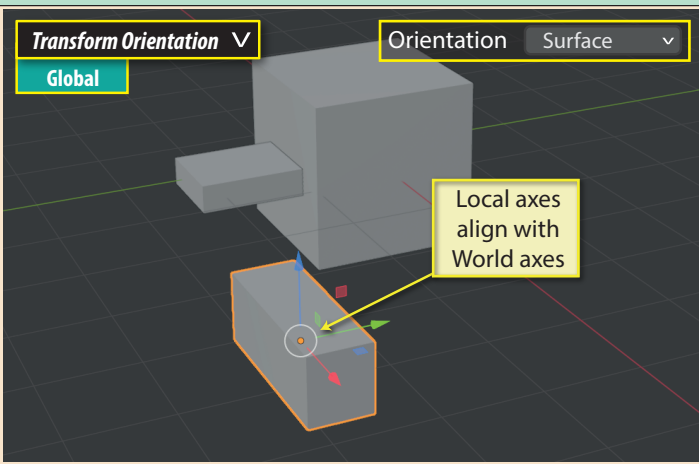

When **Transformation Orientation** is set to **Local**, then the new Cube's Local axes align with the Local axes of the last selected object.

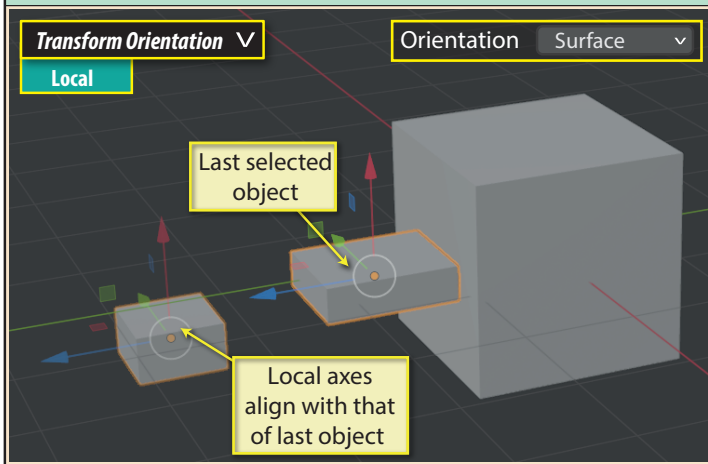

When **Orientation** is set to **Default**, then the new Cube's Local axes alignment is based solely on the Global or Local axes of the last selected item depending on the **Transformation Orientation** setting. The base alignment will not change when the mouse pointer is over an existing face.

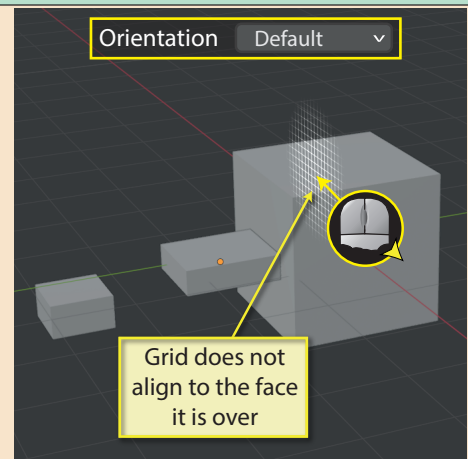
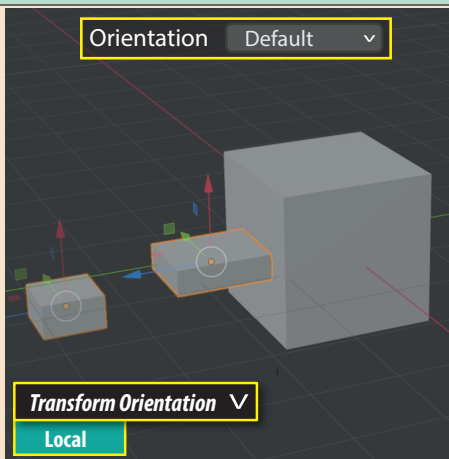
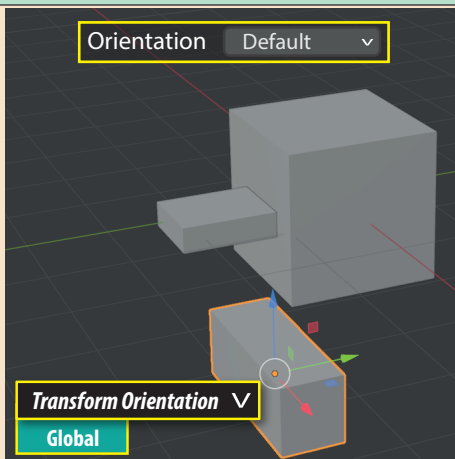

Snap To is the next parameter. Its default value is **Geometry**. This means that when we hold down the **Ctrl** key to switch on snapping the corner of the new Cube can be attached to a specific part of an existing object.

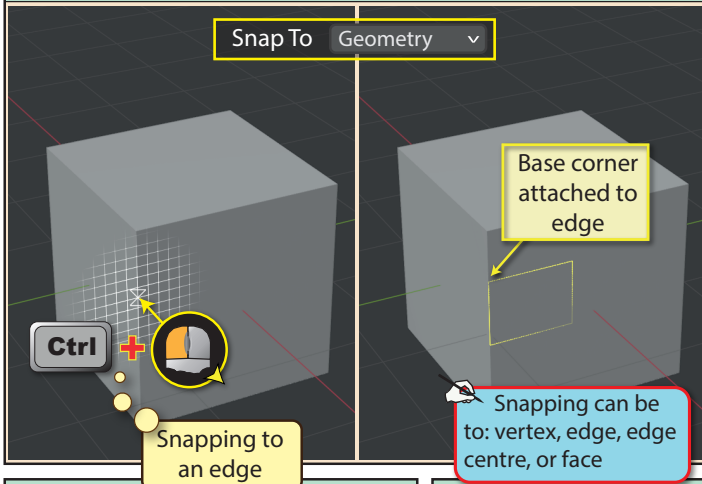

Snap To's other possible value is **Default**. When set to this, snapping for the new Cube can only be to those elements selected in the Snapping panel.

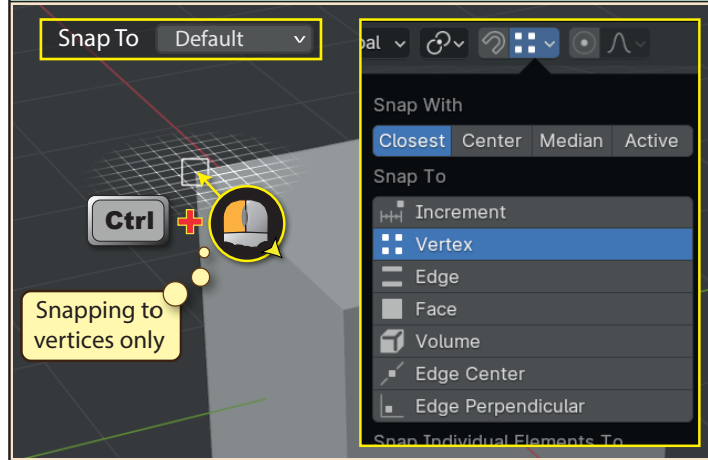

The final parameter available to Add Cube is shown as an ellipsis.

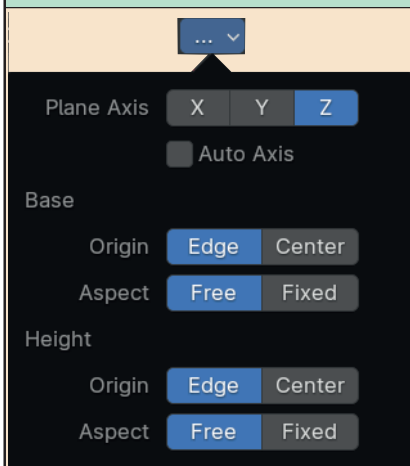

Plane Axis sets which direction the final dimension of the Cube will take.

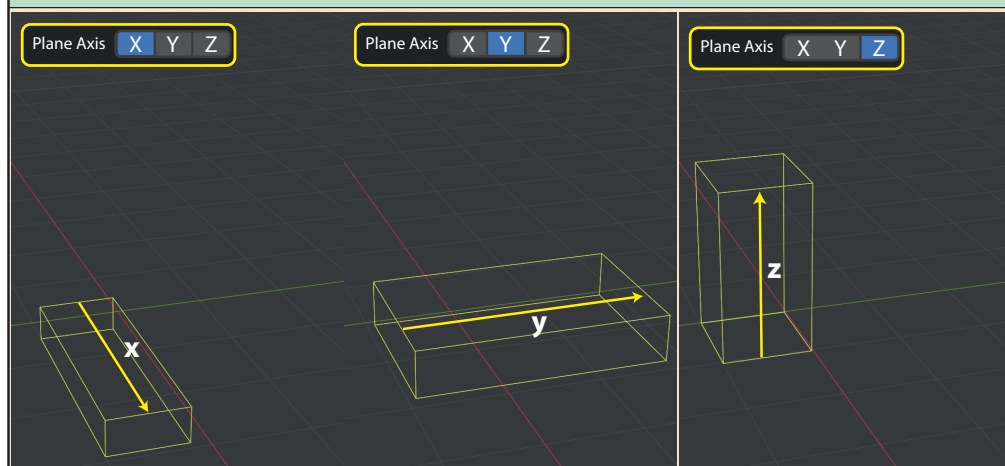

If **Auto Axis** is checked, the final dimension is determined by the viewpoint at the time of the new Cube's creation.

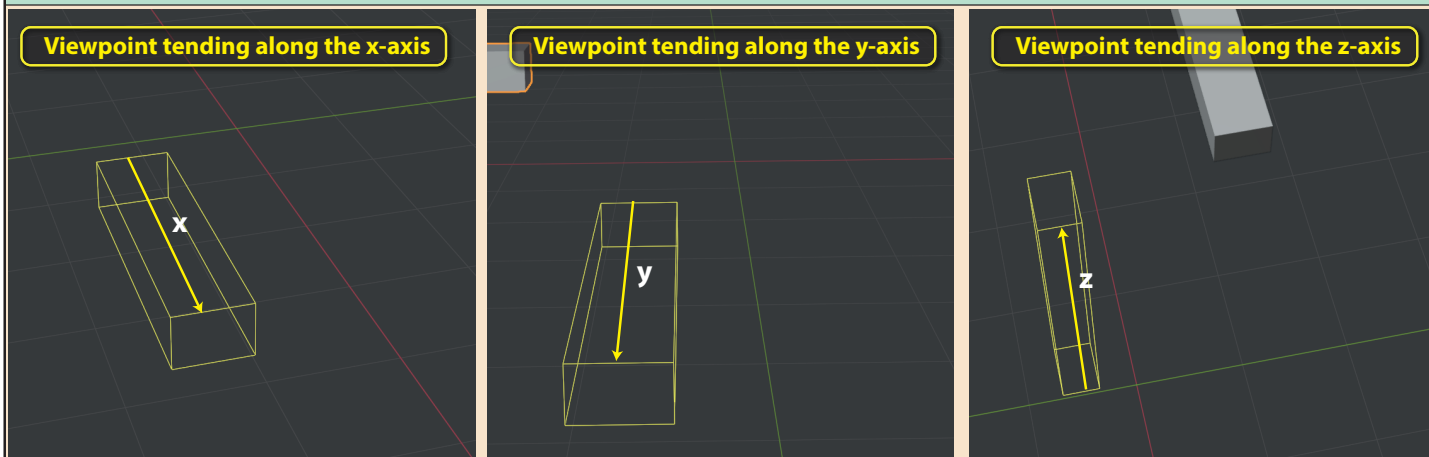

There are two parameters under the heading **Base**. **Origin** determines which part of the base the first mouse click represents. **Edge** is a base corner. **Center** is the base centre.

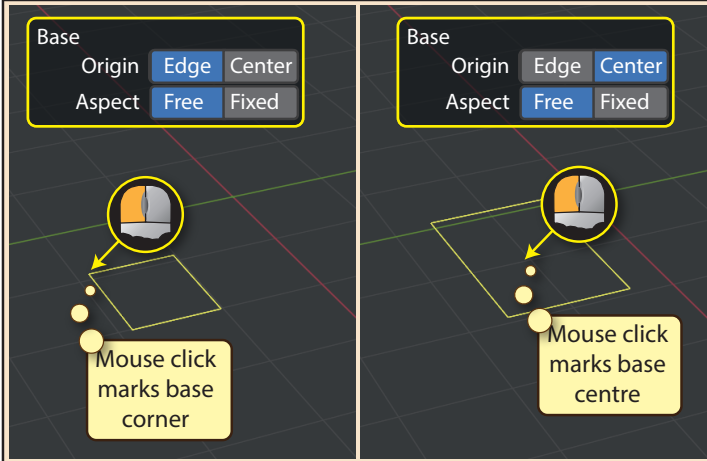

Aspect, when set to **Free** allows the base to be oblong or square; when set to **Fixed**, the base is always square as it resizes.

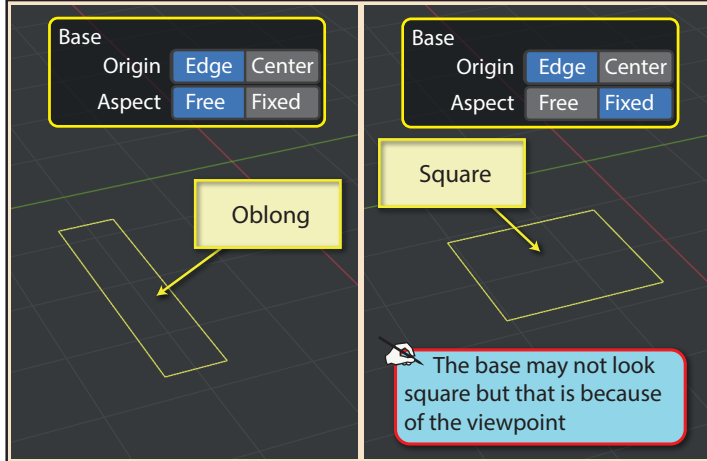

Height is the next heading in this panel. Again the two parameters are labelled **Origin** and **Aspect**. **Origin** determines if the base marks one end of the Cube (**Edge**) or its centre (**Center**).

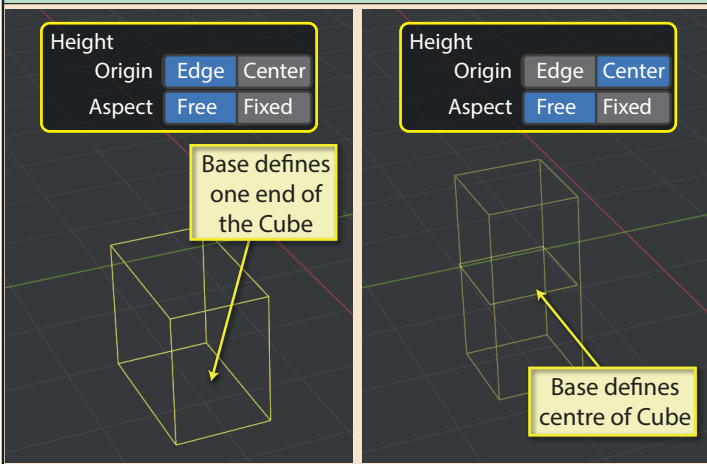

Aspect defines the Cube's third dimension. When set to **Free**, the Cube can be any length in its third dimension; when set to **Fixed**, its third dimension matches the longest of the other two dimensions.

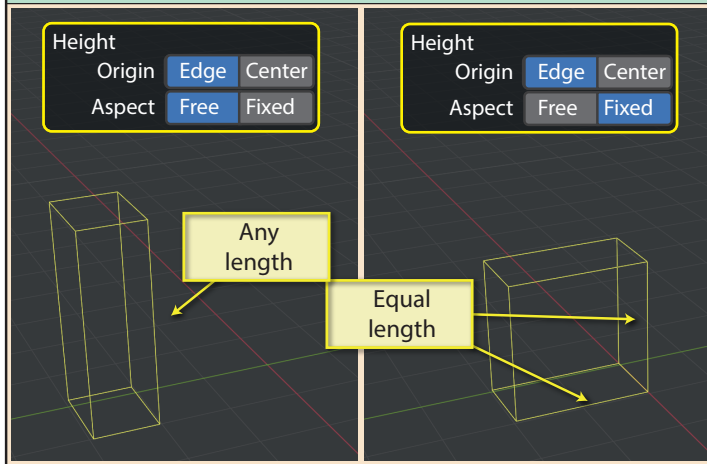

Alt is a keyboard shortcut to switch **Origin** value. This works for the Base and Height setting, depending on which part of the Cube build you are currently on.



Shift switches **Aspect** setting for the Base or Height.



Now we can move on to the **Add Cone** tool. It has two additional parameters listed.

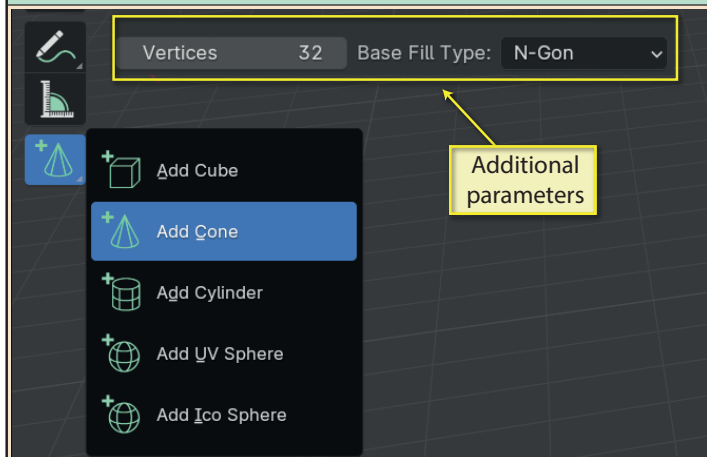

These two parameters determine the vertex count and face-fill type for any future Cones created using *Add Cone*. A newly created Cone can have its parameters adjusted in the *Last Op* panel as usual.

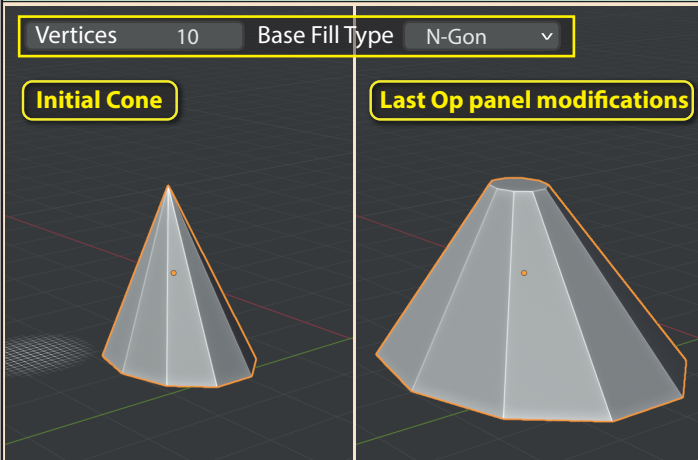

Add Cylinder has exactly the same parameters as *Add Cone*. And, like the mesh created by *Add Cone*, the base need not be circular.

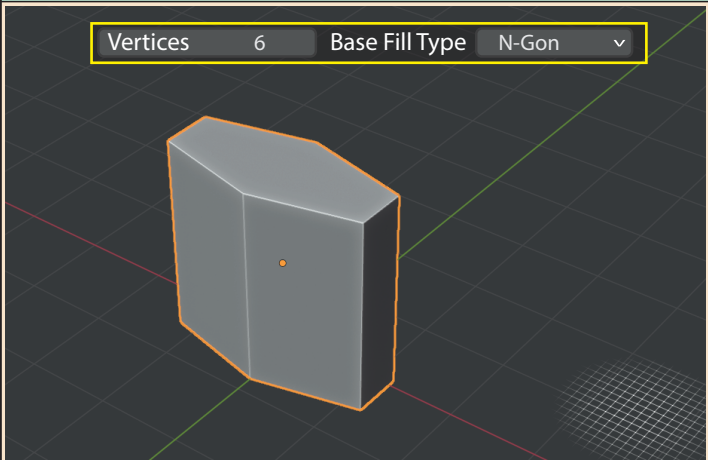

Add UVSphere has the parameters **Segments** and **Rings**. If a truly spherical shape is required, hold down the **Shift** key during its creation.

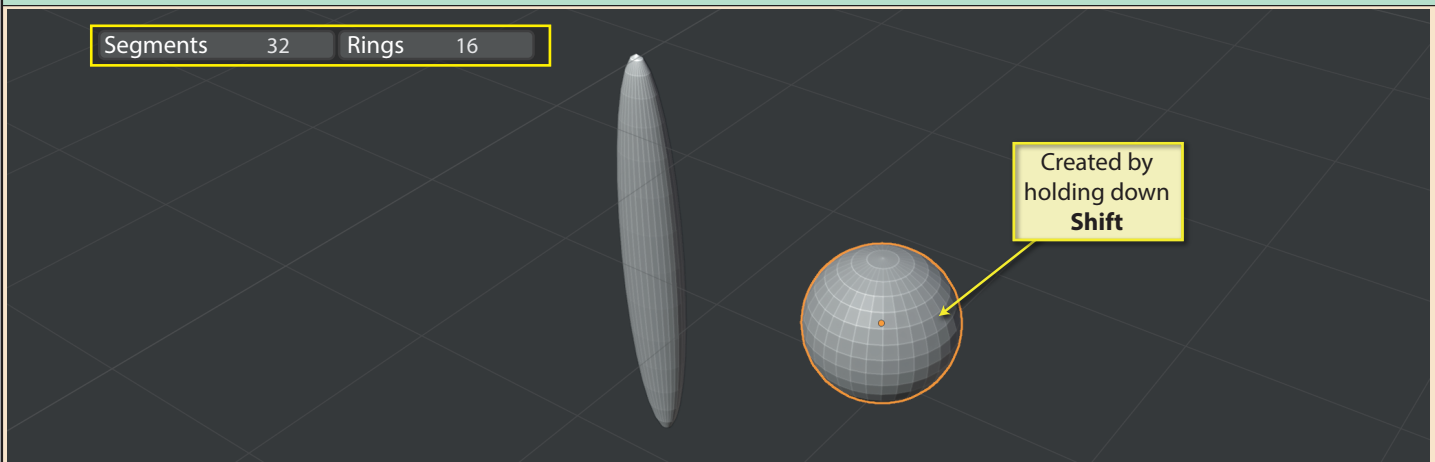

Add IcoSphere has a single parameter, **Subdivisions**. Don't set this more than a single digit as this will tax the processor and memory. Again, we need to hold down **Shift** during creation iif a spherical shape is required.

